

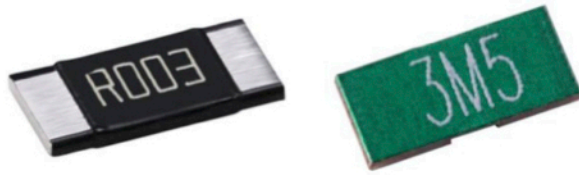

Ultra Low Ohm (Metal Strip) Chip Resistor - RUL Series

Construction



1206 & 2010

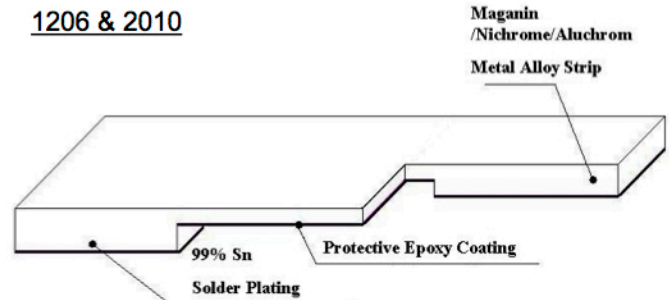

Features

- High power rating up to 3 Watts
- Low TCR down to ± 50 PPM/ $^{\circ}$ C
- Resistance values from 0.5m to 15m ohm
- Customized resistance available
- Wide range package sizes 1206 / 2010 / 2512

| Type | Material |
|-------------|--------------------------|
| 0M50~ R003 | Manganese, Copper |
| R004 ~ R010 | Aluminum, Iron, Chromium |

Applications

- NB (for Power Management)
- MB (for Power Management)
- SWPS (DC-DC Converter, Charger, Adaptor)
- Monitor (for Power Management)

2512

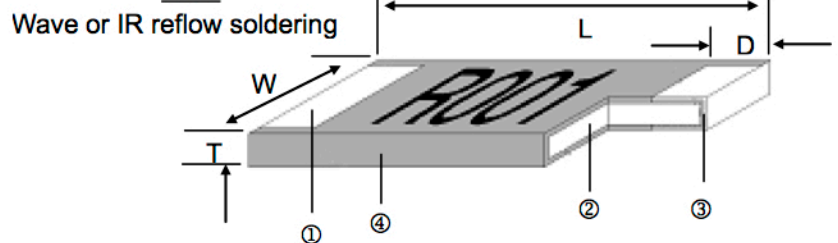

| | |
|-----------------------|----------------------|
| ① Solder Plating (Sn) | ③ Barrier Layer (Ni) |
| ② Alloy Plate | ④ Overcoat |

Derating Curve

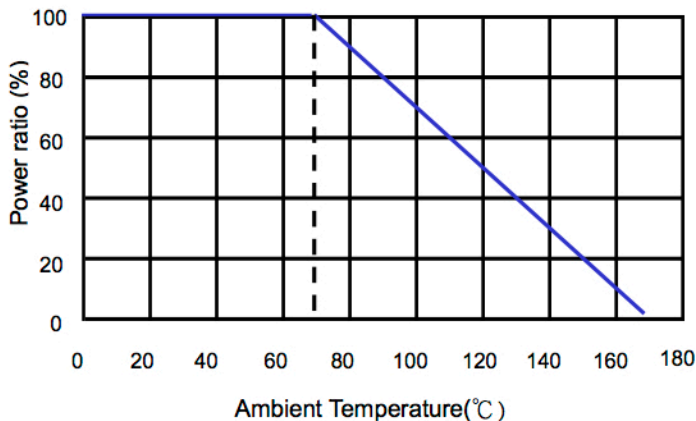

IR reflow soldering only

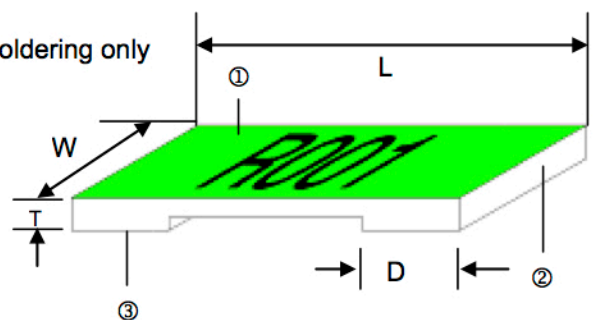

| | |
|---------------|------------------|
| ① Overcoat | ③ Solder Plating |
| ② Alloy Plate | |

■ Dimensions

Unit: mm

| | Resistance (mΩ) | L | W | T | D | Weight (g) (1000pcs) |
|----------------|-----------------------|------------|------------|-----------|-----------|----------------------|
| RUL06□0M50CTF | 0.5 | 3.20±0.25 | 1.60±0.10 | 0.60±0.20 | 1.35±0.25 | 22.6 |
| RUL06□0M75CTD | 0.75 | 3.20±0.25 | 1.60±0.10 | 0.60±0.20 | 1.23±0.25 | 22.6 |
| RUL06□□□□CT□ | 1.0 , 4.0 , 5.0 , 6.0 | 3.20±0.25 | 1.60±0.10 | 0.60±0.20 | 1.10±0.25 | 22.6 |
| RUL06□□□□CT□ | 2.0 , 3.0 , 10 | 3.20±0.25 | 1.60±0.10 | 0.60±0.20 | 0.60±0.25 | 22.6 |
| RUL06□□□□CT□ | 7.0 , 8.0 , 9.0 | 3.20±0.25 | 1.60±0.10 | 0.60±0.20 | 0.90±0.25 | 22.6 |
| RUL20□0M50CTEA | 0.5 | 5.08±0.25 | 2.54±0.15 | 0.60±0.20 | 2.17±0.25 | 42.3 |
| RUL20□0M75CTDA | 0.75 | 5.08±0.25 | 2.54±0.15 | 0.60±0.20 | 2.04±0.25 | 42.3 |
| RUL20□R001CTDA | 1.0 | 5.08±0.25 | 2.54±0.15 | 0.60±0.20 | 1.84±0.25 | 42.3 |
| RUL20□□□□CTDA | 2.0, 6.0 , 7.0 , 8.0 | 5.08±0.25 | 2.54±0.15 | 0.60±0.20 | 1.54±0.25 | 42.3 |
| RUL20□R003CTDA | 3.0 | 5.08±0.25 | 2.54±0.15 | 0.60±0.20 | 1.04±0.25 | 42.3 |
| RUL20□□□□CTDA | 4.0 , 5.0 | 5.08±0.25 | 2.54±0.15 | 0.60±0.20 | 1.84±0.25 | 42.3 |
| RUL20□□□□CTDA | 9.0 , 10 | 5.08±0.25 | 2.54±0.15 | 0.60±0.20 | 1.29±0.25 | 42.3 |
| RUL25□0M50CT□G | 0.50 | 6.35±0.25 | 3.00±0.20 | 0.60±0.20 | 2.68±0.25 | 59.13 |
| RUL25□0M75CT□G | 0.75 | 6.35±0.25 | 3.00±0.20 | 0.60±0.20 | 2.48±0.25 | 59.13 |
| RUL25□□□□CT□G | 1.0 , 6.0 | 6.35±0.25 | 3.00±0.20 | 0.60±0.20 | 1.93±0.25 | 59.13 |
| RUL25□□□□CT□G | 1.5 , 6.5 , 7.0 | 6.35±0.25 | 3.00±0.20 | 0.60±0.20 | 1.43±0.25 | 59.13 |
| RUL25□□□□CT□G | 2.0 , 3.0 | 6.35±0.25 | 3.00±0.20 | 0.60±0.20 | 1.18±0.25 | 59.13 |
| RUL25□□□□CT□G | 4.0 , 4.5 | 6.35±0.25 | 3.00±0.20 | 0.60±0.20 | 2.18±0.25 | 59.13 |
| RUL25□□□□CT□G | 5.0 , 6.0 | 6.35±0.25 | 3.00±0.20 | 0.60±0.20 | 1.93±0.25 | 59.13 |
| RUL25□□□□CT□G | 8.0 - 15 | 6.35±0.25 | 3.00±0.20 | 0.60±0.20 | 1.18±0.25 | 59.13 |
| RUL25□0M50CT□ | 0.50 | 6.35±0.254 | 3.18±0.254 | 1.25±0.20 | 1.30±0.38 | 181.10 |
| RUL25□0M75CT□ | 0.75 | 6.35±0.254 | 3.18±0.254 | 0.75±0.20 | 1.30±0.38 | 127.06 |
| RUL25□R001CT□ | 1.00 | 6.35±0.254 | 3.18±0.254 | 0.65±0.20 | 1.30±0.38 | 108.81 |
| RUL25□1M50CT□ | 1.50 | 6.35±0.254 | 3.18±0.254 | 0.45±0.20 | 1.30±0.38 | 63.92 |
| RUL25□R002CT□ | 2.00 | 6.35±0.254 | 3.18±0.254 | 0.35±0.20 | 1.30±0.38 | 46.92 |
| RUL25□2M50CT□ | 2.50 | 6.35±0.254 | 3.18±0.254 | 0.65±0.20 | 1.30±0.38 | 97.95 |
| RUL25□R003CT□ | 3.00 | 6.35±0.254 | 3.18±0.254 | 0.55±0.20 | 1.30±0.38 | 83.49 |
| RUL25□R004CT□ | 4.00 | 6.35±0.254 | 3.18±0.254 | 0.45±0.20 | 1.30±0.38 | 62.59 |
| RUL25□R005CT□ | 5.00 | 6.35±0.254 | 3.18±0.254 | 0.35±0.20 | 1.30±0.38 | 49.84 |
| RUL25□R006CT□ | 6.00 | 6.35±0.254 | 3.18±0.254 | 0.32±0.20 | 1.30±0.38 | 41.76 |
| RUL25□6M50CT□ | 6.50 | 6.35±0.254 | 3.18±0.254 | 0.30±0.20 | 1.30±0.38 | 35.85 |
| RUL25□R007CT□ | 7.00 | 6.35±0.254 | 3.18±0.254 | 0.27±0.20 | 1.30±0.38 | 34.01 |
| RUL25□R010CT□ | 10.00 | 6.35±0.254 | 3.18±0.254 | 0.25±0.20 | 1.30±0.38 | 25.97 |

Part Numbering

| RUL | 25 | J | R002 | CT | E | S | G |
|--------------|----------------------------------|----------------------------|---|-----------------|--|--|--|
| Product Type | Dimensions (L×W) | Resistance Tolerance | Resistance | Packaging Code | TCR (PPM/°C) | Power Rating | Marking |
| | 12: 1206 20: 2010 25: 2512 | F: ±1% H: ±3% J: ±5% | R002: 0.002Ω R010: 0.01Ω 0M50: 0.0005Ω 1M50: 0.0015Ω | CT: Taping Reel | D: ±50 E: ±100 W: ±75 F: ±200 | : Standard A: 1.5W B: 2.5W R: 3W S: 2W | : Black Coating G: Green Coating **2010/1206 No coating / marking |

Standard Electrical Specifications

| Part No. | Item | Power Rating at 70°C | Operating Temp. Range | Resistance Range (mΩ) | | | TCR (PPM/°C) |
|----------------|------|----------------------|-----------------------|-----------------------|-----|-----|--------------|
| | | | | ±1% | ±3% | ±5% | |
| RUL12□0M50CTF | | 1W | -55°C ~ +170°C | 0.5 | | | ±200 |
| RUL12□□□□□CTD | | 1W | | 0.75 - 10 | | | ±50 |
| RUL25□□□□□CTD | | 1W | | 0.5, 0.75, 1, 1.5, 2 | | | ±50 |
| RUL25□□□□□CTW | | 1W | | 6, 6.5, 7 | | | ±75 |
| RUL25□□□□□CTE | | 1W | | 4, 5, 10 | | | ±100 |
| RUL25□□□□□CTK | | 1W | | 2.5, 3 | | | ±150 |
| RUL25□□□□□CTDG | | 1W | | 11, 12, 13, 14, 15 | | | ±50 |

High Power Rating Electrical Specifications

| Part No. | Item | Power Rating at 70°C | Operating Temp. Range | Resistance Range (mΩ) | | | TCR (PPM/°C) |
|-----------------|------|----------------------|-----------------------|-----------------------|-----|------|--------------|
| | | | | ±1% | ±3% | ±5% | |
| RUL20□0M50CTEA | | 1.5W | -55°C ~ +170°C | 0.5 | | | ±100 |
| RUL20□□□□□CTDA | | 1.5W | | 0.75 - 10 | | | ±50 |
| RUL25□□□□□CTDS | | 2W | | 0.5, 0.75, 1, 1.5, 2 | | | ±50 |
| RUL25□□□□□CTWS | | 2W | | 6, 6.5, 7 | | | ±75 |
| RUL25□□□□□CTES | | 2W | | 4, 5, 10 | | | ±100 |
| RUL25□□□□□CTKS | | 2W | | 2.5, 3 | | | ±150 |
| RUL25□□□□□CTDSG | | 2W | | 6.5, 7, 8, 9, 10 | | | ±50 |
| RUL25□□□□□CTDBG | | 2.5W | | 4, 4.5, 5, 6 | | | ±50 |
| RUL25□□□□□CTDRG | | 3W | | 1, 1.5, 2, 3 | | | ±50 |
| RUL25□□□□□CTERG | | 3W | 0.5, 0.75 | | | ±100 | |

Operating Current = $\sqrt{(P/R)}$, Operating Voltage = $\sqrt{(P \cdot R)}$

Cal-Chip has the ability to manufacture the following options based on customer requirements.

Resistance codes example

Resistance (3Marking)

| Resistance | 0.5mΩ | 0.75mΩ |
|------------|-------|--------|
| Codes | M50 | M75 |

Resistance (4Marking)

| Resistance | 1mΩ | 1.5mΩ | 2mΩ | 7mΩ | 10mΩ |
|------------|------|-------|------|------|------|
| Codes | R001 | 1M50 | R002 | R007 | R010 |

Reflow

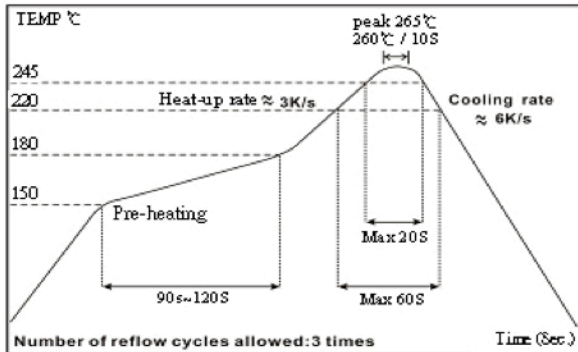

- Green coating "Reflow Air Convection" is available
- Green coating can't be working with wave soldering bath

Environmental Characteristics

| Item | Requirement | | Test Method |
|--|-------------------|---------------|--|
| | Black coating | Green coating | |
| Temperature Coefficient of Resistance (T.C.R.) | As Spec. | | MIL-STD-202 Method 304 +25/-55/+25/+125/+25°C |
| Short Time Overload | ±0.5% | ±1% | JIS-C-5201-1 5.5 5*rated power for 5 seconds |
| Endurance | ±1% | ±1% | MIL-STD-202 Method 108A 70±2°C, RCWV for 1000 hrs with 1.5 hrs "ON" and 0.5 hrs "OFF" |
| Dry Heat | ±1% | ±1% | JIS-C-5201-1 7.2 at +170°C for 1000 hrs |
| Solderability | 95% min. coverage | | MIL-STD-202 Method 208H 245±5°C for 3 seconds |
| Resistance to Soldering Heat | ±0.5% | ±1% | MIL-STD-202 Method 210E 260±5°C for 10 seconds |
| Thermal Shock | ±0.5% | ±1% | MIL-STD-202 Method 107G -55°C ~ 150°C, 100 cycles |

**Green coating can't be work with wave soldering bath.

RCWV(Rated continuous working voltage)= $\sqrt{P \cdot R}$ or Max. Operating voltage whichever is lower

Storage Temperature: 25±3°C; Humidity < 80%RH

■ Measurements Unit: mm

1. RUL25 4-wire precision measurement (Black Coating)

- Equipment: ADEX AX-1152D DC Low Ohm Meter
- Excitation Current: 3A (0.5mΩ~1.5 mΩ)
1A (2mΩ~10mΩ)

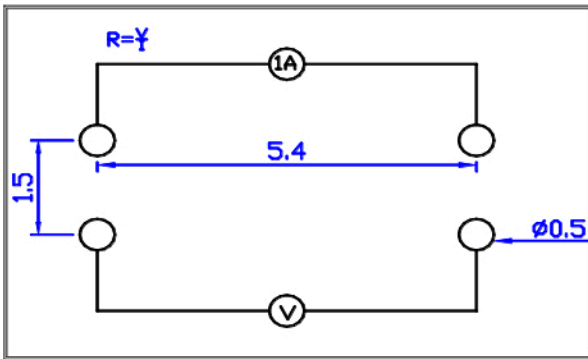

2. RUL25 4-wire pad layout (recommended for precision current sensing)

- Note: No circuits between pads to avoid short circuit

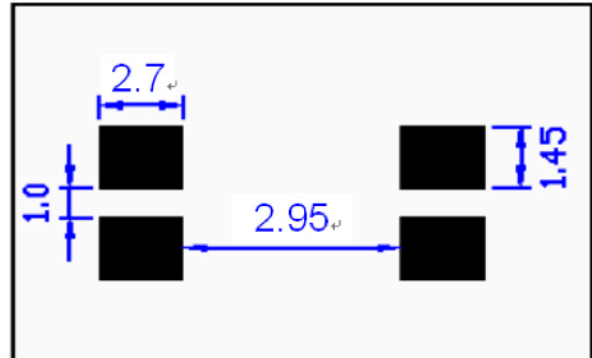

3. RUL25 2-wire pad layout

- Note: No circuits between pads to avoid short circuit

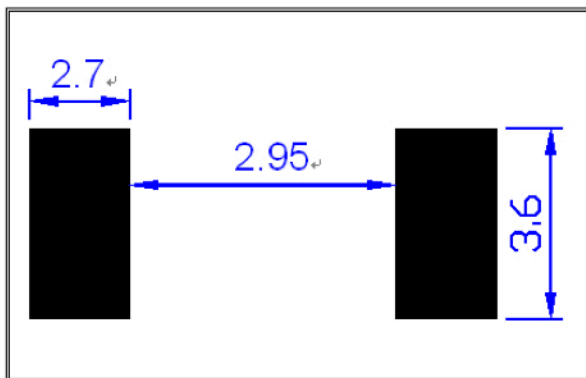

4. RUL25 4-wire precision measurement (Green Coating)

- Equipment: ADEX AX-1152D DC Low Ohm Meter
- Excitation Current: 3A (0.5mΩ~1.5 mΩ)
1A (2mΩ~15mΩ)

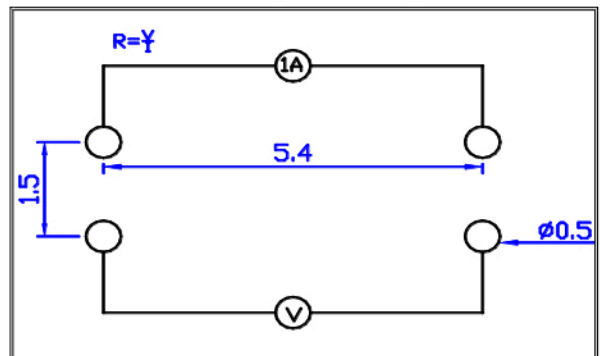

5. RUL25 4-wire pad layout (recommended for precision current sensing)

- Note: No circuits between pads to avoid short circuit

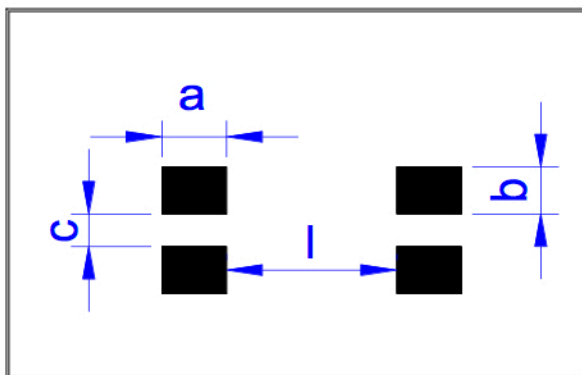

Unit: mm

| Item Type | a m/m | b m/m | C m/m | l m/m |
|-----------|-------|-------|-------|-------|
| 0M50 | 3.13 | 1.2 | 1.0 | 0.52 |
| 0M75 | 2.93 | 1.2 | 1.0 | 0.94 |
| R001 | 2.38 | 1.2 | 1.0 | 2.04 |
| 1M5 | 1.88 | 1.2 | 1.0 | 3.04 |
| R002~R003 | 1.63 | 1.2 | 1.0 | 3.54 |
| R004~4M5 | 2.63 | 1.2 | 1.0 | 1.54 |
| R005~R006 | 2.38 | 1.2 | 1.0 | 2.04 |
| 6M5~R007 | 1.88 | 1.2 | 1.0 | 3.04 |
| R008~R015 | 1.63 | 1.2 | 1.0 | 3.54 |

9. RUL12 2-wire pad layout

■ Note: No circuits between pads to avoid short circuit

Unit: mm

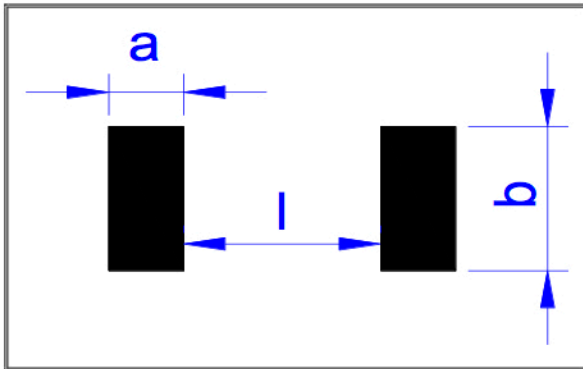

| Item Type | a m/m | b m/m | l m/m |
|-----------|-------|-------|-------|
| 0M50 | 1.80 | 1.90 | 0.55 |
| 0M75 | 1.68 | 1.90 | 0.55 |
| R001 | 1.55 | 1.89 | 0.55 |
| R002~R003 | 1.05 | 1.89 | 1.55 |
| R004~R006 | 1.55 | 1.89 | 0.55 |
| R007~R009 | 1.35 | 1.89 | 0.95 |
| R010 | 1.05 | 1.89 | 1.55 |

10. RUL20 4-wire precision measurement

- Equipment: ADEX AX-1152D DC Low Ohm Meter
- Excitation Current: 3A (0.5mΩ~1.5mΩ)
1A (2mΩ~10mΩ)

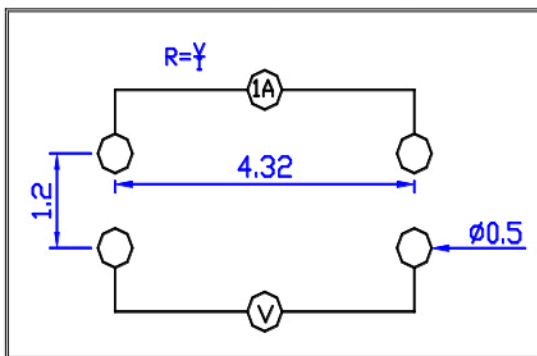

11. RUL20 4-wire pad layout (recommended for precision current sensing)

■ Note: No circuits between pads to avoid short circuit

Unit: mm

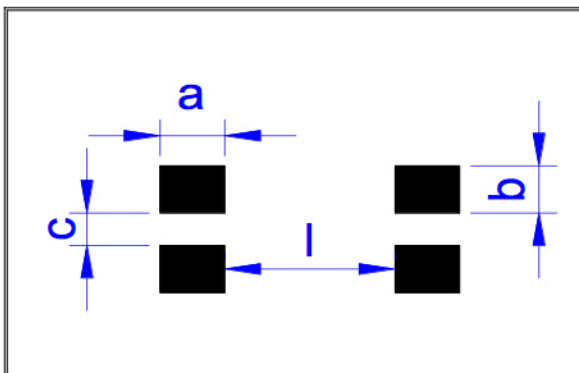

| Item Type | a m/m | b m/m | C m/m | l m/m |
|-----------|-------|-------|-------|-------|
| 0M50 | 2.61 | 1.045 | 0.8 | 0.60 |
| 0M75 | 2.49 | 1.045 | 0.8 | 0.80 |
| R001 | 2.29 | 1.045 | 0.8 | 0.95 |
| R002 | 1.99 | 1.045 | 0.8 | 1.55 |
| R003 | 1.49 | 1.045 | 0.8 | 2.55 |
| R004~R005 | 2.29 | 1.045 | 0.8 | 0.95 |
| R006~R008 | 1.99 | 1.045 | 0.8 | 1.55 |
| R009~R010 | 1.74 | 1.045 | 0.8 | 2.05 |

12. RUL20 2-wire pad layout

■ Note: No circuits between pads to avoid short circuit

Unit: mm

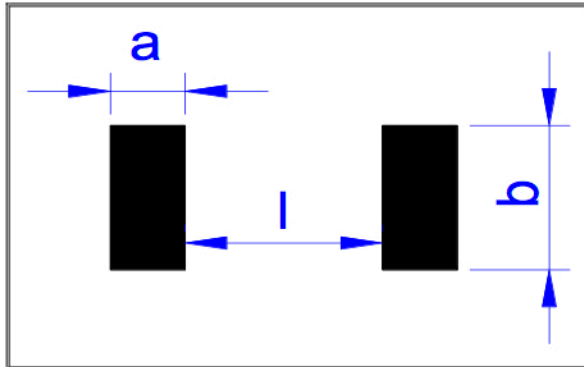

| Item Type | a m/m | b m/m | l m/m |
|--------------|----------|----------|----------|
| 0M50 | 2.61 | 2.89 | 0.60 |
| 0M75 | 2.49 | 2.89 | 0.80 |
| R001 | 2.29 | 2.89 | 0.95 |
| R002 | 1.99 | 2.89 | 1.55 |
| R003 | 1.49 | 2.89 | 2.55 |
| R004~R005 | 2.29 | 2.89 | 0.95 |
| R006~R008 | 1.99 | 2.89 | 1.55 |
| R009~R010 | 1.74 | 2.89 | 2.05 |

■ Packaging

Embossed Plastic Tape Specifications

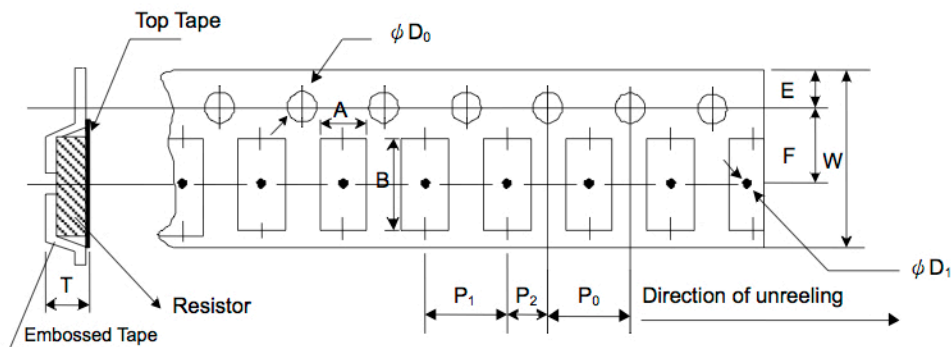

Unit: mm

| Type | Resistance (m Ω) | A | B | W | E | F | P ₀ | P ₁ | P ₂ | ΦD_0 | ΦD_1 | T | Quantity (EA) |
|-----------|-----------------------------|----------|----------|----------|----------|----------|----------------|----------------|----------------|------------|------------|----------|------------------|
| RUL12 | 0.5 - 10 | 1.90±0.1 | 3.60±0.1 | 8.0±0.2 | 1.75±0.1 | 3.5±0.05 | 4.0±0.1 | 4.0±0.1 | 2.0±0.05 | 1.55±0.05 | 1.0min. | 0.87±0.1 | 2,000 |
| RUL20 | 0.5 - 10 | 2.85±0.1 | 5.55±0.1 | 12.0±0.2 | 1.75±0.1 | 5.5±0.05 | 4.0±0.1 | 4.0±0.1 | 2.0±0.05 | 1.55±0.05 | 1.4min. | 0.85±0.1 | 2,000 |
| RUL25 | 0.50 - 0.75 | 3.40±0.1 | 6.75±0.1 | 12.0±0.1 | 1.75±0.1 | 5.5±0.05 | 4.0±0.1 | 4.0±0.1 | 2.0±0.05 | 1.55±0.05 | 1.4min. | 1.45±0.2 | 2,000 |
| | 1 - 10 | | | | | | | | | | | 0.81±0.1 | |
| RUL25 (G) | 0.50 - 15 | 3.40±0.1 | 6.75±0.1 | 12.0±0.1 | 1.75±0.1 | 5.5±0.05 | 4.0±0.1 | 4.0±0.1 | 2.0±0.05 | 1.55±0.05 | 1.4min. | 0.81±0.1 | 2,000 |

1. The cumulative tolerance of 10 sprockets hole pitch is ± 0.2 mm.
2. Carrier camber shall be not more than 1mm per 100mm through a length of 250mm.
3. A & B measured 0.3mm from the bottom of the packet
4. T measured at a point on the inside bottom of the packet to the top surface of the carrier.
5. Pocket position relative to sprocket hole is measured as the true position of the pocket and not the pocket hole.