

MULTILAYER CHIP SUPPRESSORS (CHIP BEADS)

- FBH SERIES -

FEATURES

- FBH Series for DC Power Line
- Rated Current: 1-3.5A
- Operating Temp -55 - 125°C
- The FBH series can be used on high current circuits due to its low DC resistance. It can match power lines to a maximum of 3.5A DC.



APPLICATIONS

- High current DC Power Line EMI suppress. Examples:
 - CD-ROM'S
 - Hard Drives
 - Modems
 - Monitors
 - Motherboards
 - Printers

SHAPES AND DIMENSIONS

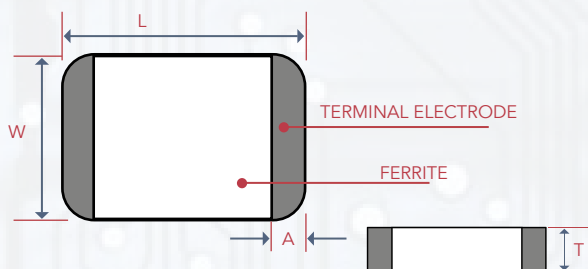

SHAPE	L (MM)	W (MM)	T (MM)	A (MM)
100505 (0402)	1.0 ± 0.05	0.5 ± 0.05	0.5 ± 0.05	0.1~0.3
160808 (0603)	1.6 ± 0.15	0.8 ± 0.15	0.8 ± 0.15	0.2~0.6
201209 (0805)	2.0 ± 0.2	1.25 ± 0.2	0.9+0.15/-0.2	0.2~0.8
321611 (1206)	3.2 ± 0.2	1.6 ± 0.2	1.1 ± 0.2	0.4~1.0
322513 (1210)	3.2 ± 0.2	2.5 ± 0.2	1.3 ± 0.2	0.6~1.0
451616 (1806)	4.5 ± 0.2	1.6 ± 0.2	1.6 ± 0.2	0.6~1.0
453215 (1812)	4.5 ± 0.2	3.2 ± 0.2	1.5 ± 0.2	0.6~1.0

ORDERING INFORMATION

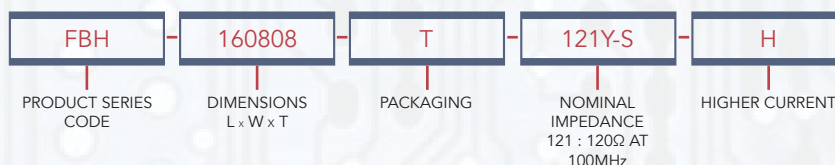

EQUIVALENT CIRCUIT DIAGRAM

- FBH series for DC Power Line
- Rated Current: 1-3A



PACKAGING GUIDE

SERIES	PART NUMBER	PCS PER REEL
FBH	100505 (0402)	10000 /R
FBH	160808 (0603)	4000 /R
FBH	201209 (0805)	4000 /R
FBH	321611 (1206)	3000 /R
FBH	322513 (1210)	2000 /R
FBH	451616 (1806)	2000 /R
FBH	453215 (1812)	1000 /R

ELECTRICAL CHARACTERISTICS - 1005

PART NUMBER	IMPEDANCE (Ω) $\pm 25\%$ [100MHz]	DC RESISTANCE Ω (MAX)	RATED CURRENT mA (MAX)
FBH100505T-100Y-S	10	0.03	2000
FBH100505T-300Y-S	30	0.05	1700
FBH100505T-300Y-S-H	30	0.03	3000
FBH100505T-330Y-S	33	0.04	3000
FBH100505T-600Y-S	60	0.075	1500
FBH100505T-600Y-S-H	60	0.07	2500
FBH100505T-700Y-S	70	0.09	1200
FBH100505T-101Y-S	100	0.09	1200
FBH100505T-121Y-S	120	0.09	1200
FBH100505T-121Y-S-H	120	0.09	2000
FBH100505T-181Y-S	180	0.14	1000

ELECTRICAL CHARACTERISTICS - 1608

PART NUMBER	IMPEDANCE (Ω) $\pm 25\%$ [100MHz]	DC RESISTANCE Ω (MAX)	RATED CURRENT mA (MAX)
FBH160808T-190Y-S	19	0.04	3000
FBH160808T-220Y-S	22	0.04	3000
FBH160808T-300Y-S	30	0.04	3000
FBH160808T-310Y-S	31	0.04	3000
FBH160808T-330Y-S	33	0.04	3000
FBH160808T-500Y-S	50	0.04	3000
FBH160808T-600Y-S	60	0.04	3000
FBH160808T-700Y-S	70	0.04	3000
FBH160808T-800Y-S	80	0.04	3000
FBH160808T-101Y-S	100	0.04	3000
FBH160808T-121Y-S	120	0.04	3000
FBH160808T-151Y-S	150	0.04	3000
FBH160808T-181Y-S	180	0.06	2000
FBH160808T-221Y-S	220	0.08	2000
FBH160808T-301Y-S	300	0.10	2000
FBH160808T-471Y-S	470	0.20	1000
FBH160808T-601Y-S	600	0.30	1200
FBH160808T-102Y-S	1000	0.25	1000



ELECTRICAL CHARACTERISTICS - 2012

PART NUMBER	IMPEDANCE (Ω) $\pm 25\%$ [100MHz]	DC RESISTANCE Ω (MAX)	RATED CURRENT mA (MAX)
FBH201209T-070Y-S	7	0.03	3000
FBH201209T-100Y-S	10	0.03	3000
FBH201209T-170Y-S	17	0.03	3000
FBH201209T-310Y-S	31	0.03	3000
FBH201209T-470Y-S	47	0.03	3000
FBH201209T-500Y-S	50	0.03	3000
FBH201209T-520Y-S	52	0.03	3000
FBH201209T-600Y-S	60	0.04	3000
FBH201209T-800Y-S	80	0.04	3000
FBH201209T-101Y-S	100	0.04	3000
FBH201209T-121Y-S	120	0.05	3000
FBH201209T-181Y-S	180	0.05	3000
FBH201209T-221Y-S	220	0.05	3000
FBH201209T-301Y-S	300	0.05	3000
FBH201209T-331Y-S	330	0.05	3000
FBH201209T-471Y-S	471	0.10	2000
FBH201209T-601Y-S	600	0.10	2000
FBH201209T-751Y-S	750	0.12	1500
FBH201209T-102Y-S	1000	0.30	1000
FBH201209T-152Y-S	1200	0.30	1000
FBH201209T-152Y-S-H	1500	0.30	1500

ELECTRICAL CHARACTERISTICS - 3216

PART NUMBER	IMPEDANCE (Ω) $\pm 25\%$ [100MHz]	DC RESISTANCE Ω (MAX)	RATED CURRENT mA (MAX)
FBH321611T-190Y-S	19	0.03	3000
FBH321611T-310Y-S	31	0.03	3000
FBH321611T-520Y-S	52	0.03	3000
FBH321611T-600Y-S	60	0.03	3000
FBH321611T-700Y-S	70	0.04	3000
FBH321611T-800Y-S	80	0.04	3000
FBH321611T-900Y-S	90	0.04	3000
FBH321611T-101Y-S	100	0.04	3000
FBH321611T-121Y-S	120	0.05	3000
FBH321611T-151Y-S	150	0.05	3000
FBH321611T-181Y-S	180	0.05	3000
FBH321611T-201Y-S	200	0.05	3000
FBH321611T-221Y-S	220	0.05	3000
FBH321611T-301Y-S	300	0.06	3000
FBH321611T-501Y-S	500	0.07	2500
FBH321611T-501Y-S-H	500	0.06	3000
FBH321611T-601Y-S	600	0.08	2000
FBH321611T-601Y-S-H	600	0.07	2500
FBH321611T-102Y-S	1000	0.30	1000
FBH321611T-122Y-S	1200	0.20	1000

ELECTRICAL CHARACTERISTICS - 3225

PART NUMBER	IMPEDANCE (Ω) $\pm 25\%$ [100MHz]	DC RESISTANCE Ω (MAX)	RATED CURRENT mA (MAX)
FBH322513T-520Y-S	52	0.03	3000
FBH322513T-600Y-S	60	0.03	3000
FBH322513T-102Y-S	1000	0.09	2000

ELECTRICAL CHARACTERISTICS - 4516

PART NUMBER	IMPEDANCE (Ω) $\pm 25\%$ [100MHz]	DC RESISTANCE Ω (MAX)	RATED CURRENT mA (MAX)
FBH451616T-600Y-S	60	0.04	3000
FBH451616T-750Y-S	75	0.04	3000
FBH451616T-800Y-S	80	0.04	3000
FBH451616T-101Y-S	100	0.04	3000
FBH451616T-151Y-S	150	0.04	3000
FBH451616T-181Y-S	180	0.04	3000
FBH451616T-181Y-S-H	180	0.04	3500
FBH451616T-601Y-S	600	0.09	2000
FBH451616T-851Y-S	850	0.15	1500
FBH451616T-102Y-S	1000	0.09	1500

ELECTRICAL CHARACTERISTICS - 4532

PART NUMBER	IMPEDANCE (Ω) $\pm 25\%$ [100MHz]	DC RESISTANCE Ω (MAX)	RATED CURRENT mA (MAX)
FBH453215T-700Y-S	70	0.04	3000
FBH453215T-800Y-S	80	0.04	3000
FBH453215T-121Y-S	120	0.04	3000
FBH453215T-151Y-S	150	0.04	3000

PART NUMBER	IMPEDANCE (Ω) $\pm 25\%$ [50MHz]	DC RESISTANCE Ω (MAX)	RATED CURRENT mA (MAX)
FBH453215T-601Y-S	600	0.04	3000

PART NUMBER	IMPEDANCE (Ω) $\pm 25\%$ [60MHz]	DC RESISTANCE Ω (MAX)	RATED CURRENT mA (MAX)
FBH453215T-132Y-S	1300	0.04	3000



ENVIRONMENTAL CHARACTERISTICS

ELECTRICAL PERFORMANCE TEST

ITEM	SPECIFICATION	TEST METHODS
Impedance	Refer to standard electrical spec.	- HP4286A
DCR		- HP 4338 digital mili-ohm meter

MECHANICAL PERFORMANCE TEST

ITEM	SPECIFICATION	TEST METHODS
Substrate Bending Test	<ul style="list-style-type: none"> - Without deformation cases - Impedance: within $\pm 30\%$ of initial value - DC Resistance shall be satisfied 	<ul style="list-style-type: none"> - Test device shall be soldered on the substrate - Substrate Dimension: 100x40x0.8mm - Deflection: 3.0mm - Keeping Time: 10sec and then return
Vibration	<ul style="list-style-type: none"> - Appearance: No damage - Impedance: within $\pm 30\%$ of initial value - DC Resistance shall be satisfied 	<ul style="list-style-type: none"> - Test device shall be soldered on the substrate - Oscillation Frequency : 10 to 55 to 10Hz for 1min - Amplitude : 1.5mm(peak-peak) - Time : 2hrs for each axis (X,Y&Z), total 6hrs
Resistance to Soldering Heat	<ul style="list-style-type: none"> - No visible damage - Electrical characteristics and mechanical characteristics shall be satisfied 	<ul style="list-style-type: none"> - Solder temp: 265\pm5$^{\circ}$C - Immersion time: 6\pm1sec - Preheating: 100$^{\circ}$C to 150$^{\circ}$C, 1 minute - Measured after exposure in the room condition for 24hrs - Solder: Sn-3Ag-0.5Cu
Solderability	- 95% min. coverage of all metallized area	<ul style="list-style-type: none"> - Solder Temperature: 240\pm5$^{\circ}$C - Immersion Time: 3\pm1sec - Solder: Sn-3Ag-0.5Cu
Terminal Strength	<ul style="list-style-type: none"> - Without deformation cases - Impedance: within $\pm 30\%$ of initial value - DC Resistance shall be satisfied 	<ul style="list-style-type: none"> - Solder chip on PCB and applied 10N (1.02KgF) for 10 sec
Temperature Cycle		<ul style="list-style-type: none"> One cycle: <ul style="list-style-type: none"> - One cycle/step1: -55\pm3$^{\circ}$C for 30\pm3min step2: standard atmospheric conditions 5s or less step3: 125\pm2$^{\circ}$C for 30\pm3min step4: standard atmospheric conditions 5s or less - Total: 100cycles - Measured after exposure in the room condition for 24hrs
Humidity Resistance	<ul style="list-style-type: none"> - Appearance: No damage - Impedance: within $\pm 30\%$ of initial value DC Resistance shall be satisfied 	<ul style="list-style-type: none"> - Temperature: 60\pm2$^{\circ}$C - Relative Humidity: 90 ~ 95% - Applied Current: Rated Current(maximum value) - Time: 1008\pm12hrs - Measured after exposure in the room condition for 24hrs
High Temperature Resistance		<ul style="list-style-type: none"> - Temperature: 125\pm2$^{\circ}$C - Applied Current: Rated Current(maximum value) - Time: 1008\pm12hrs - Measured after exposure in the room condition for 24hrs
Low Temperature Storage Life Test		<ul style="list-style-type: none"> - Temperature: -55\pm2$^{\circ}$C - Time: 1008\pm12hrs - Measured after exposure in the room condition for 24hrs
Thermal Shock		<ul style="list-style-type: none"> - -55$^{\circ}$C~125$^{\circ}$C kept stabilized for 30 minutes each for 100 cycles - Measured after exposure in the room condition for 24hrs

- Operating Temperature: -55 $^{\circ}$ C ~ 125 $^{\circ}$ C
- Storage Temperature: 15~28 $^{\circ}$ C ; Humidity < 80%RH

PACKAGING

- Reel Specifications

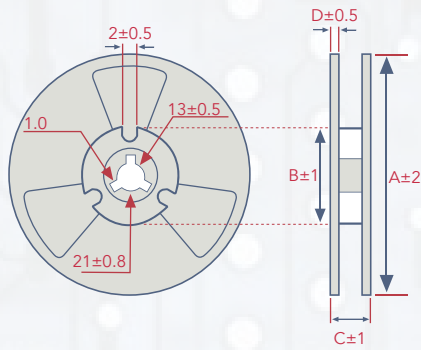

- Tape Specifications

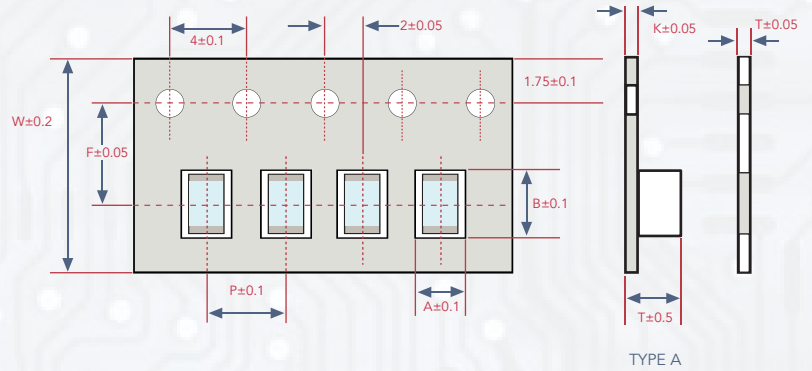

- Tape Material

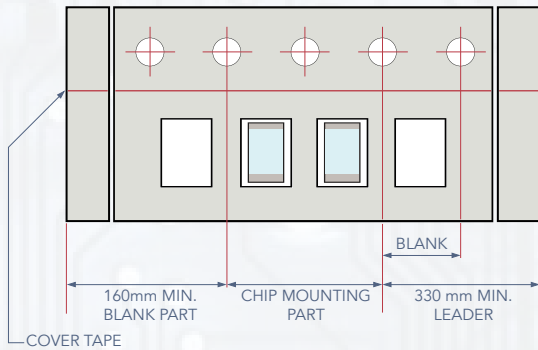

- Recommended Pattern

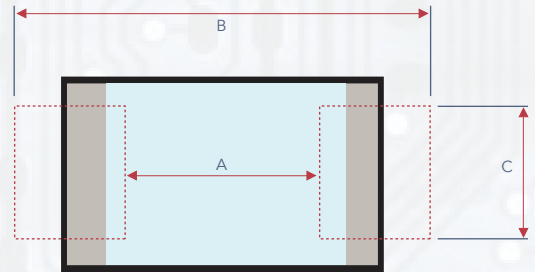

Unit : mm

TYPE	TAPE DIMENSIONS								REEL DIMENSIONS				RECOMMENDED PATTERN			QUANTITY (EA)
	A	B	T	W	P	F	K	TAPE TYPE	A	B	C	D	A	B	C	
FBH060303	0.38	0.68	1.10	8.0	2.0	3.5	-	B	178	60	10	2	0.25	0.69	0.32	15000
FBH100505	0.65	1.15	0.80	8.0	2.0	3.5	-	B	178	60	10	2	0.50	2.10	0.55	10000
FBH160808	1.10	1.90	1.10	8.0	4.0	3.5	-	B	178	60	10	2	0.60	2.60	0.80	4000
FBH201209	1.55	2.30	1.20	8.0	4.0	3.5	-	B	178	60	10	2	0.66	3.23	1.47	4000
FBH321611	1.90	3.50	1.40	8.0	4.0	3.5	0.2	A	178	60	10	2	2.20	4.40	2.06	3000
FBH321616	1.88	3.64	1.90	8.0	4.0	3.5	0.2	A	178	60	10	2	2.20	4.2-5.2	1.2	2000
FBH322513	2.90	3.60	1.70	8.0	4.0	3.5	0.2	A	178	60	10	2	2.13	4.06	2.74	2000
FBH451616	2.90	4.90	1.40	12	4.0	5.5	0.3	A	178	60	14	2	2.70	5.70	2.24	2000
FBH453215	3.60	4.90	2.05	12	8.0	5.5	0.3	A	178	60	14	2	2.57	5.90	4.22	1000

SOLDERING CONDITION

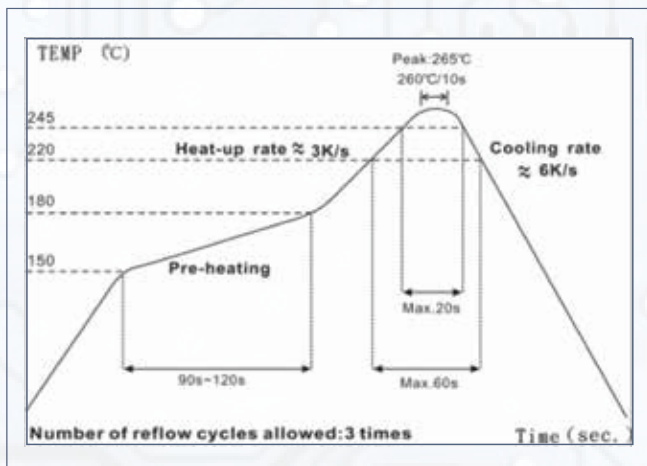

IR Reflow Soldering

(1) Time of IR reflow soldering at maximum temperature point 260°C zzz: 10s

(2) Time of soldering iron at maximum temperature point 280°C : 3s

